

DESIGN AND CONSTRUCTION OF A SMART MICROCONTROLLER TEMPERATURE-BASED FAN SPEED CONTROLLER USING ATMEGA_{328P} MICROCONTROLLER AND LIQUID CRYSTAL DISPLAY (LCD)

Amadi Christopher Chidi, Nnamdi Henry Ifeanyi

Department of Computer Engineering, Michael Okpara University of Agriculture, Umudike

*Corresponding author, email: amadi.christopher@mouau.edu.ng

doi: 10.17977/um068.v5.i2.2025.2

Keywords

Temperature
Liquid Crystal Display (LCD)
Electric Fan
Automation
Microcontroller Speed Controller System

Abstract

The rapid growth in technology and the introduction of various microcontroller chips has resulted in design of various control systems. The ability to automatically change the speed of fan in respect to change in the temperature of the surrounding would allow the user to feel comfort without physically to change the speed of fan. This article involves the design and develop a smart microcontroller temperature-based fan speed controller system using Atmega328p microcontroller and liquid crystal display (LCD) that controls the speed of the fan based on the temperature of the environment and display readout using the LCD. The goal of this research is to enable an electric fan to change its speed level automatically in response to temperature changes in the environment. The designed technology creates an atmosphere in which the fan speed is controlled by the system rather than the user. That is the fan automatically regulates itself by sensing the temperature of the room and adjusting itself to suit the temperature of the room. This system consists of temperature sensor, liquid crystal display (LCD) and other relevant electronic components with integration of software programming using ATMEGA328P as the microcontroller. The electric fan automatically switches the speed according to the ambient temperature changes using the temperature sensor LM35. If the temperature is between (18-22) °c, it gives a logic high signal at the output 1 i.e. Relay 1. If the temperature is between (22-28) °c, it gives a logic high signal at the output 2 i.e. Relay 2. If the temperature is between (28-32) °c, it gives a logic high signal at the output 3 i.e. Relay 3. If the temperature is below the lowest temperature and above the highest temperature, it gives a logic low signal at all outputs it will also presents the expected performance of the automatic fan system, construction of hardware and software development to gather the performance data. Finally, this system performance will be analyzed by comparing performance data to the theoretical end. It produced an advance technology with programmable features and control where the speed of the fan is depending on the changes in room temperature.

1. INTRODUCTION

An electric fan is an electrical device that produces airflow for the purpose of creating comfort, ventilation, exhaust, or any other gaseous transport. Meanwhile, a ceiling fan is a device suspended from the ceiling of a room, which employs hub-mounted rotating paddles to circulate air to produce a cooling effect. The first ceiling fans appeared in the 1860s and 1870s, in the United States, Charlse J. A and Matthew N.S. (2004). At that time, they were not powered by any form of electric motor, but instead, a stream of running water was used, in conjunction with a turbine, to drive a system of belts which would turn the blades of two-blade fan units. Afterwards, the electrically powered ceiling fan was invented in 1882 by Philip Diehl, Adel. S.K., and Barren Smith (2007). Electric fans are designed to create a breeze and circulate air in a room.

A good fan can make a room feel 10-15 degrees cooler when used properly. Electric fans are simple in their design and function. An electric motor spins the blades, which are shaped to move air from the back of the fan out through the front of the fan, Anuel. S and Chabra. K, (2000). The important

parts of a fan are the electric motor, paddles or blades, and switches. Since a fan creates its cooling effect by speeding, thus, the most important part of a fan is its speed controller. Electric fans come in different ways of operating methods, which depend on the manufacturer and style. This article can have a huge impact on helping people continuously without the interference of people in changing the speed level of the fans. Moreover, switching Fan regulators more often through manual control may damage the regulator. Not only that, but this project can also help disabled people who are sometimes unable to reach the controller that controls the fan speed. Therefore, having such a project can serve many people and ensure their convenience in interacting with some of the machines that people deal with nowadays, such as the machine used in this project, which is the fan.

Industrial electronics is a holistic aspect of modern world technology; as such, most of the electronically advanced countries like the USA, Japan, Russia, etc. cannot sustain their technological advancement without the subject mentioned above. The advent of microelectronics in 1959 by Jack Kilby gave rise to the birth of both linear and digital circuits, like Operational Amplifiers, Voltage Regulators, IC Timers, Combinational Logic, Structural and Sequential Logic ICs, among a host of other digital system components. A microcontroller integrated with an auto coupler that senses the bottled beer can control and automate batch counters for the bottling process.

The discovery of the microcontroller in 1972 marked the beginning of microprogram control in electronics (Angelo, 1969). Microprocessors like 8080, 8086, 8088; Pentium, etc, were employed for microprogram control of batch counters in the 20th century, but microcontrollers became preferable for such embedded applications for control systems, in contrast to the microprocessors, which are better for general-purpose applications. The control mechanism of this batch counter is realized through a microprogram control. The microprogram, which is the driving software, is written in assembly language and flashed into the 8951 microcontrollers.

This article demonstrates how microcontrollers can be used in real-world appliances. One practical example is incorporating a microcontroller in a temperature control system to control a room's temperature automatically. When selecting a fan for an application, it must be designed for worst-case conditions. This means choosing a fan that can move enough air to keep the system sufficiently cool even with worst-case ambient temperature, power dissipation, fan production tolerances, and fan aging.

A temperature controller is a closed-loop control system that senses the temperature of the environment. It compares it with a user-fed threshold temperature value and changes the speed of the fan accordingly. A temperature controller is a closed-loop control system that senses the temperature of the environment. It compares it with a user-fed threshold temperature value and changes the speed of the fan accordingly. Such of product prototype is of great importance in industrial applications, as a slight or abrupt change in the required temperature may bring voids in the functioning of systems or deteriorate the quality of the product being manufactured. Office Buildings, Auditoriums, Nuclear Plants, and Pharmaceutical Industries, including Greenhouse Buildings, can make use of this intelligent technology.

There are three main functions of this system:

- To monitor the recent value of temperature within the set range using the temperature sensor.
- To track the changes in temperature to change the speed of the fan proportionally.
- To display actual temperature values in degrees Celsius.

Tschudi (2007) has presented an air handler fan speed control system. This demonstration was one part of a multi-part Digital Realty (DLR) program to increase energy efficiency. It was built on the success of a previously completed Public Interest Energy Research (PIER)-sponsored pilot project at the California Franchise Tax Board data center in 2009. That project demonstrated efficiency gains using speed control on fans contained in computer room air handlers (CRAHs). Digital Realty is headquartered in San Francisco, California. This project's goal was to show that the energy-efficiency success achieved with the same technology for CRAH fan speed control used in the 2009 pilot project (Bell, 2009) could scale to large enterprise data centers. The 2009 project

demonstrated a control system provided by Vigilant as part of the Emerging Technology Demonstration Grants Program (Tschudi, 2009).

This project demonstrates the same Vigilant system (control system) in a much larger facility. DLR owns the data center selected for this demonstration. It is 135,000 square feet (ft²) and divided into nine active colocation rooms (Colos) containing IT equipment operated and provided by multiple customers.

1.1. The CRAH Basics

Computer room air handlers provide cooling to meet environmental requirements for IT equipment. They are commonly placed on the periphery of the room or specifically located depending on the data center room shape. Data center operators should follow environmental guidelines published by the American Society of Heating, Refrigerating and Air-Conditioning Engineers (ASHRAE). ASHRAE recommends operating temperatures ranging from 18°C–27°C (64.4°F–80.6°F) and allows up to 90 percent relative humidity in some cases for IT equipment cooling air.

Mustafa Saad (2014) has presented an automatic fan speed control system using a microcontroller. This paper describes the design and construction of the control system that controls the fan speed as the change of the room temperature takes place. One of the most important concerns involved in the heat area consists of the desired temperature achievement and consumption optimization. The fan can be controlled manually by pressing the switch button. In this method, any change in the temperature will not give any change in the fan speed. Except for the usage change, the speed of the fan is manually controlled. So, an automatic temperature control system technology is needed for controlling purpose in the fan speed according to temperature changes. When the temperature variation, after some time, its efficiency may be decreased.

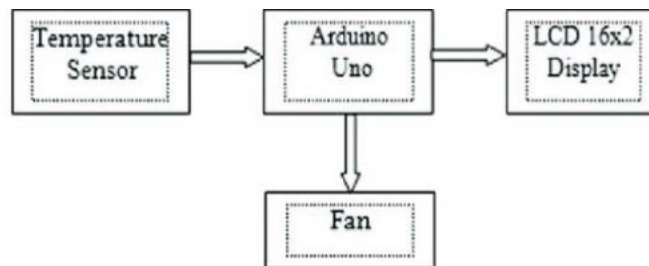

Figure 1. System block Diagram of an Automatic fan speed control system using a microcontroller

In 2015, EDGEFX TEAM represented on the edgfx kits website a system to control the fan speed using a TV remote, with a thyristor power control method. This is done by sending data from the TV remote to the control panel, which receives signals from the sensor. When you press any button on the remote control, the system sends encrypted data via infrared. Then, the data is implemented by the controller. The power for the system is connected in series with the thyristor that is controlled based on the signals received. 7 segments are shown on the screen at an angle. In this study, a lamp is provided instead of the fan for demonstration purposes only. Limitation: This idea is rigid because the infrared resulting from the remote-control devices is spread over large areas. Therefore, it can control the range of devices using one remote control. Therefore, if you put the sensor regulator near the TV, the fan speed can be changed whenever the remote control is set to control another device. Figure 2.2 is the circuit diagram of fan speed control by TV remote.

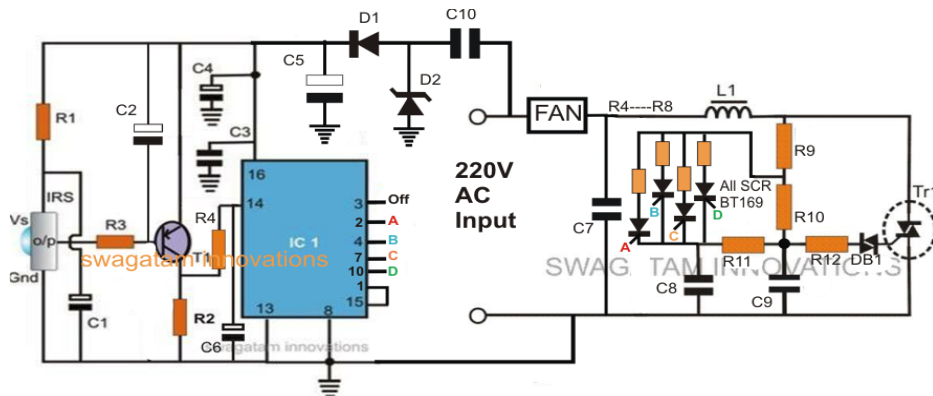

Figure 2. Fan speed control by TV remote (<https://makingcircuits.com/wp-content/uploads/2016/10/IR-fan-dimmer-circuit.png>).

The project can be enhanced by adding more outputs from the microcontroller feeding relay drivers to switch on/off domestic loads and control the fan's speed.

2. METHODS

This project uses many materials, mainly electronic components, both passive and active. The materials and methods used in this article are explained below.

2.1. Atmega328P

ATmega328 is a single-chip microcontroller created by Atmel in the Mega Advanced Virtual RISC (AVR family). It can handle data of up to eight (8) bits. ATmega328 has 32KB of internal memory. There are several other features on this microcontroller, including 1KB Electrically Erasable Programmable Read-Only Memory on the ATmega-328 (EEPROM). It has a modified Harvard architecture 8-bit RISC processor core. The Atmel 8-bit AVR RISC-based microcontroller combines 32 KB ISP flash memory with read-while-write capabilities, 1 KB EEPROM, 2 KB SRAM, 23 general-purpose I/O lines, 32 general-purpose working registers, three flexible timer/counters with compare modes, internal and external interrupts, serial programmable USART, a byte-oriented 2-wire serial interface, SPI serial port, 6-channel 10-bit A/D converter (8-channels in TQFP and QFN/MLF packages), programmable watchdog timer with internal oscillator, and five software selectable power saving modes. The device operates between 1.8- 5.5 volts. The device achieves throughput approaching 1 MIPS per MHz. In Atmega328P, 6 ADC channels can be used to convert the analog signal to digital. This microcontroller is used in this article because of the features it possesses: advanced RISC architecture, good performance, low power consumption, real timer counter having a separate oscillator, 6 PWM pins, programmable Serial USART, programming lock for software security, throughput up to 20 MIPS, etc. The diagram and the architecture of the microprocesses are as shown in Figures 3.1 and 3.2, respectively.



Figure 3. Diagram of an ATMEGA328P Microcontroller. (<https://www.digipart.com/part/atmega328p>)

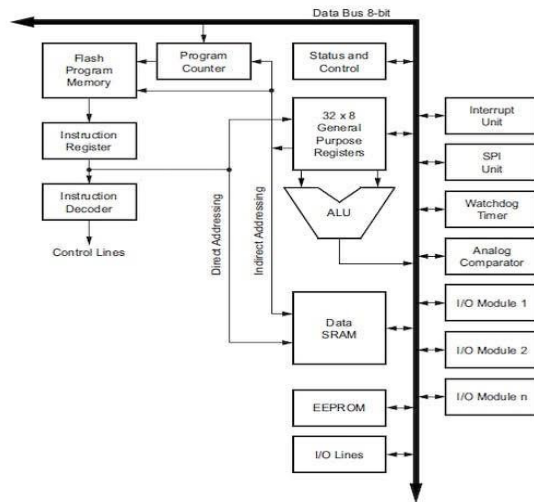

Fig. 4. Architecture of Atmega328p

2.2. Motor Driver unit: The output stage comprises the alarm, display, and motor driver unit.

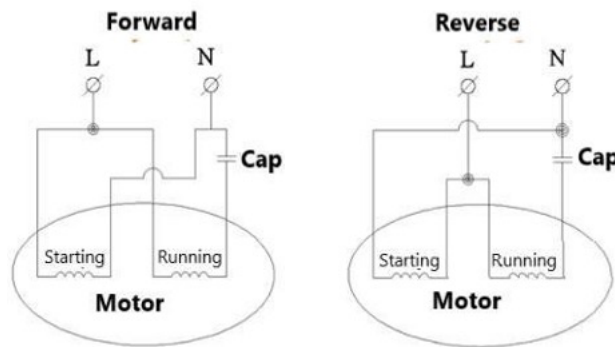

Fig 4. Motor direction changing circuit

2.3. Resistors

The resistor is one of the most common and yet important components used in electronics. A resistor is a two-terminal electronic component that produces a voltage across its terminals that is proportional to the electric current through it in accordance with Ohm's law. In this project work, many resistors were used, depending on their values and functions. Some resistors were used as pull-up resistors, some served as biasing resistors, and some were used to either increase or reduce the sensitivity of the transducer.

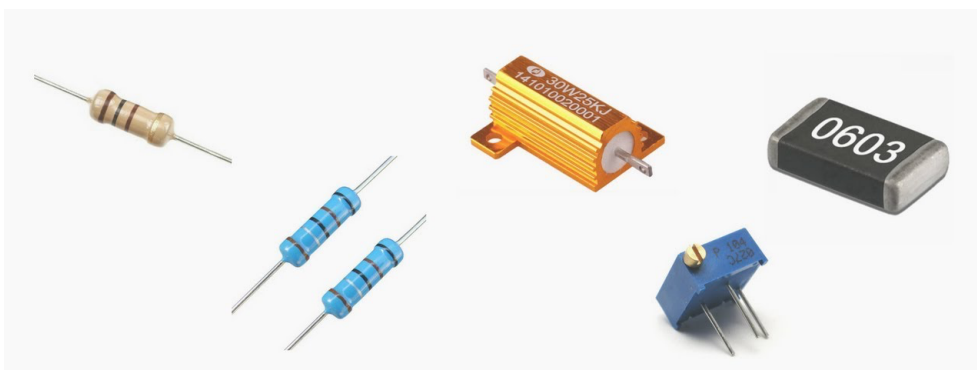

Figure 5. variable and fixed resistor

Temperature sensor (LM35). It is the most widely used sensor for sensing temperature. The output relates to the analog channel (RA1) from the microcontroller's port RA. The sensor measures temperature with an electrical output proportional to the temperature. Specifications: Operator from 4 to 30 volts, Low impedance output, 0.1 ohm for 1mA load, Rated for full -55 to 150 °C range.

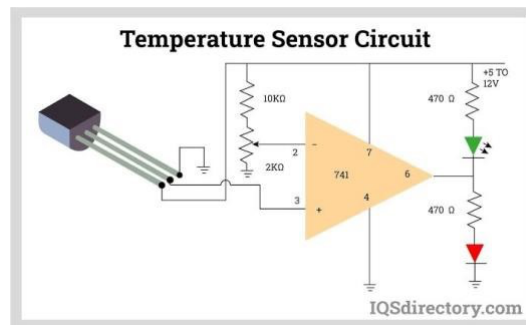

Figure 6. Temperature Sensor Unit

2.4. Transistors

Transistors are semiconductor devices used for applications like amplification of voltages, and are also used as switches. It is a two-function and three-terminal device made of three layers of N and P-type semiconductors. There are different types of transistors, but for the sake of this project work, we will concentrate on bipolar junction transistors.

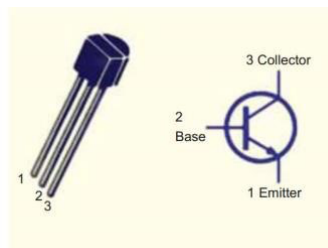

Figure 7. Transistors

2.5. 2x16 LCD Module

The LCD (Liquid Crystal Display) screen is an electronic display module and finds a wide range of applications. A 16x2 LCD is a very basic module and is very commonly used in various devices and circuits. These modules are preferred over seven-segment and other multi-segment LEDs. The reasons being: LCDs are economical; easily programmable; have no limitation of displaying special & even custom characters (unlike in seven segments), animations, and so on.

2.6. TRIAC

It is a semiconductor device; it has a 3-terminal for controlling the current. It uses an AC switching application because it can control the current flow over both alternating cycles. Also, it is used for controlling the speed of the fan. Specifications:

- Low power
- Gate voltage = 1.5v
- Gate current = 25mA
- Peak-off voltage = 500v
- ON state current = 4.0A
- Interface 4 to 8 busses

This paper presents the design and simulation of the fan speed control system using the pulse width modulation technique based on room temperature. A temperature sensor measures the room temperature, and the fan speed is varied according to it. The duty cycle is varied from 0 to 100 to control the fan speed.

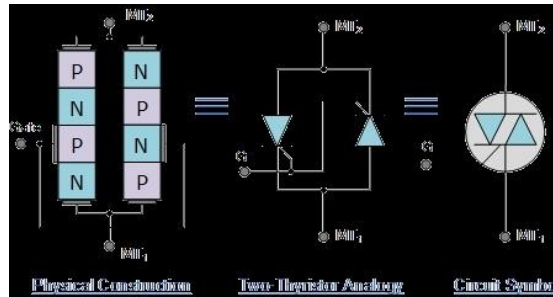

Depending upon the room temperature, which is displayed on a Liquid Crystal Display (LCD). When taking on a new electronics project, it is important to carefully organize the methods in which the project must be performed. Because there can be various systems and subsystems to deal with, it is best to break the systems down into smaller, manageable tasks to complete. In putting together our project, we chose to approach it by segmenting it in terms of hardware procedures and software procedures. When building the temperature control system, I prepared a workspace that could accommodate the tools, equipment, and materials that were required for the project. By clearing a large area on my desk, I placed a soft absorbing cloth across the workspace so that any loose materials would not easily roll off the desktop in the event of any parts or pieces becoming loose to bounce and bouncing off the desk. The soft material can absorb any stray moving components and catch them before they get lost. This prepared me to take the necessary steps in getting ready for the assembly of the project. Our main source of instruction in building the circuit was to follow the schematic we generated by using MultiSim. After populating the breadboard with the 2N3904 transistors and resistors, we applied +5 volts through the circuit to simulate the controller sending the voltage coming from the microcontroller. We were able to get 3 different voltage outputs to the fan, which would represent a fan speed at each stage. The transistors would act as an electronic switch that, when triggered, would open the 12V supply to the fan.

3. RESULTS AND DISCUSSION.

The system was meticulously implemented in phases. These involve two major phases as discussed below.

3.1. The Hardware Implementation Phase:

The component that makes up the system building block of the microcontroller-based automatic speed control system of the fan, based on the room temperature, includes resistors, capacitors, transistors, a relay, a microcontroller module, an LCD, and others were properly assembled according to the circuit diagram in chapter three. In testing the functionality of these components, this implies assembling them properly and implementing them according to the specification of what is required. The AVO meter was good for testing individual components. However, there were cases where some ICs were placed wrongly and were correctly immediately when discovered. Having assembled the various components that make up both the transmitter and receiver circuits and properly soldered their components to their respective positions and accurately, the project was packaged in such a manner that it would be portable, durable, and well covered to avoid water inlet.

3.2. The microcontroller module

The microcontroller module mainly consists of the Arduino Nano Microcontroller board. This module is responsible for collecting data from the sensor module, converting the data received into a pulse, and then sending the result to the LCD through the USB to UART cable.

3.3. The Software Implementation Phase

Software development is the development of software. This software could be produced for a variety of purposes. The most common purposes are to meet the specific needs of a specific client/business, to meet a perceived need of some set of potential users, or for personal use (e.g., the software used to drive this project). The term software development is often used to refer to the activity of computer programming, which is the process of writing and maintaining source code. In contrast, the broader sense of the term includes all that is involved between the conception of the

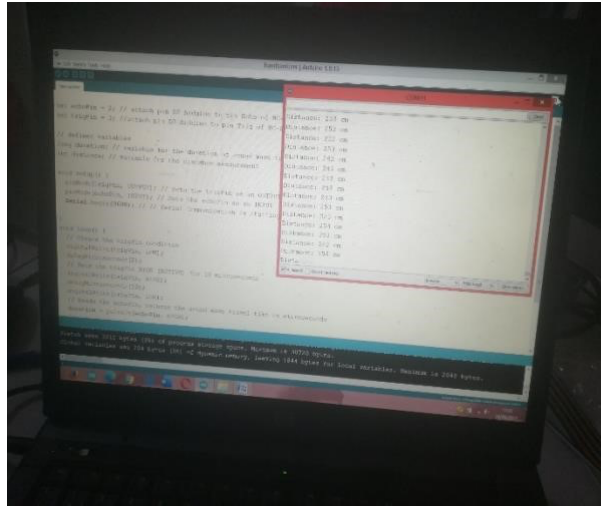

Figure 9. The system outputs to the Arduino Serial Monitor.

The second result was obtained when the whole system was tested after integrating the hardware and software phases. The result of this test is shown in the figure below.

5. CONCLUSION

The purpose of this article was to create a design that would automatically alter the speed of a fan in response to changes in the ambient temperature of the surroundings. The Smart microcontroller temperature-based fan speed controller was built using Atmega328p. The system circuit was built using a Vero board, and all the other components were joined. It was put to the test as a DC fan. The results of the test revealed that the fan performed admirably at the specified speed. Moreso, temperature-based ceiling fan speed regulators are very practical because they can be moved around and are of high benefit to the blind/location within the house with one transmitter. This system is of high precision and durability, such that it can easily be marketed. In this present age, every organization needs a control system for bridging the gap between the host and its destination. We have successfully programmed the microcontroller to control the fan speed based on the surrounding temperature conditions. The output speed of the fan and temperature of the room have been displayed on the LCD, and an automatic ON/OFF control system of the fan based on the presence of people inside the room was also included.

REFERENCES

- Adel, S. K., & Barren Smith. (2007). *Microelectronic circuits*. Oxford University Press.
- Angelo, E. J. (1969). *Electronics: BJTs, FETs, and microcircuits*. <http://ci.nii.ac.jp/ncid/BA1290202X>
- Anuel, S., & Chabra, K. (2000). *Fundamentals of digital electronics and microprocessors*. Schuaund Publishers Limited.
- Godse, A. P. (2014). *Microprocessor and interfacing*. <https://www.amazon.com/MICROPROCESSOR-INTERFACING-P-Godse/dp/935038096X>
- Babatunde, J. D. (2022). Microcontroller-based temperature-controlled DC fan using ATMEGA328. *Engineering and Technology Journal*, 7(6). <https://doi.org/10.47191/etj/v7i6.07>
- Bai, Y. (2016). *Microcontroller engineering with MSP432: Fundamentals and applications*. <https://www.amazon.com/Microcontroller-Engineering-MSP432-Fundamentals-Applications/dp/1498772986>
- Barrett, S. F., & Pack, D. J. (2006). *Microcontrollers: Fundamentals for engineers and scientists. Synthesis Lectures on Digital Circuits and Systems*, 1(1), 1–124. <https://doi.org/10.2200/s00025ed1v01y200605dcs001>
- Bhatia, V., & Bhatia, G. (2013). Room temperature-based fan speed control system using pulse width modulation technique. *International Journal of Computer Applications*, 81(5), 35–40. <https://doi.org/10.5120/14011-2067>
- Gao, W., Emaminejad, S., Nyein, H. Y. Y., Challa, S., Chen, K., Peck, A., Fahad, H. M., Ota, H., Shiraki, H., Kiriya, D., Lien, D. H., Brooks, G. A., Davis, R. W., & Javey, A. (2016). Fully integrated wearable sensor arrays for multiplexed in situ perspiration analysis. *Nature*, 529(7587), 509–514. <https://doi.org/10.1038/nature16521>
- Microcontroller-based temperature monitoring and control. (2002). *Elsevier eBooks*. <https://doi.org/10.1016/b978-0-7506-5556-9.x5000-2>
- Mohite, S., Adsule, S., Patil, R., & Dhawas, N. (2020). Automatic temperature-based fan speed controller using Arduino. *Social Science Research Network*. <https://doi.org/10.2139/ssrn.3645388>

Saad, M. (2014). Microcontroller interfacing with electrical components. Retrieved from Electrical Circuits Designs website: <http://www.electricalcircuitsdesigns/About/about.htm>

Sedra, A. S., & Smith, K. C. (2007). *Microelectronic circuits* (Revised ed.). <https://dl.acm.org/citation.cfm?id=1537213>

Schuster, A. (2008). *Microcontroller principles and applications*. Maxon Press Ltd.